

**PUOLOP 迪浦**

**PTB O165CXXS**

**8bit IO-Type Controller**

***Data Sheet***

## Table of Contents

<b>1. Introduction</b> .....	<b>4</b>
1.1. Function Compare Table.....	4
<b>2. Pin Definition</b> .....	<b>4</b>
<b>3. RF Inverters Functional Description</b> .....	<b>5</b>
3.1. Register Setting .....	5
3.2. Code Example .....	5
<b>4. RFC (Resistance to Frequency Converter) Functional Description</b> .....	<b>6</b>
4.1. Register Setting .....	7
4.1.1. RFC <i>Control Register (rfcc)</i> .....	7
4.1.2. RFC Counter <i>Result High Register (rfcchr)</i> .....	7
4.1.3. RFC Counter <i>Result Low Register (rfcchl)</i> .....	7
4.2. Code Example .....	7
4.3. R-Type .....	8
4.4. C-Type .....	11

**Revision History:**

Revision	Date	Description
0.01	2017/8/31	1 <sup>st</sup> Version

**IMPORTANT NOTICE**

**PTB0165CXXS is NOT designed for AC RC step-down powered, high power ripple or high EFT requirement application. Please do NOT apply PTB0165CXXS to those application application products.**

## 1. Introduction

The PTB0165CXXS not only derives all basic functions from PTB0154CXXS, the additional features also include two IO inverters for 27- 40MHz RF communication decoding , and maximum 10 channels R-type and C-type RFC(Resistance to Frequency Converter) for resistive or capacitive measurement such as resistive ID or human touch sensing. This datasheet only describes the additional functions in PTB065CXXS . For more understanding about the basic functions, please refer to the PTB0154CXXS datasheet.

### 1.1. Function Compare Table

Function	PTB0165CXXS	PTB0154CXXS
Basic Functions	●	●
IO Inverters	●	X
RFC	●	X

## 2. Pin Definition

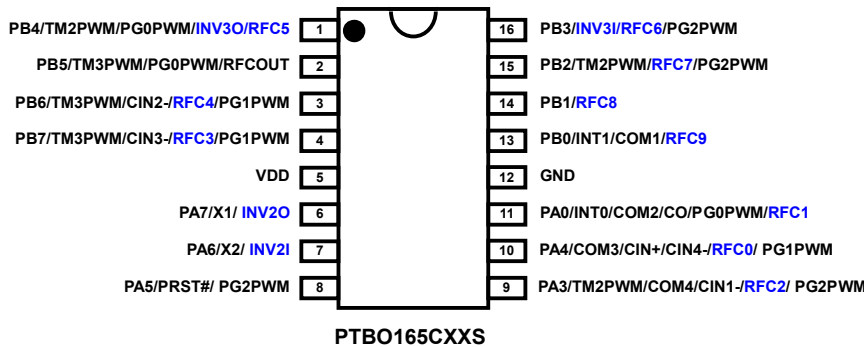

### 3. RF Inverters Functional Description

#### 3.1. Register Setting

MISC2 Register (misc2) :

Bit	Reset	R/W	Description
7 - 3	-	-	Reserved
2	0	WO	Enable INV3I (PB3) / INV3O (PB4) function. 0 / 1 : disable / enable
1	0	WO	Enable INV2I (PA6) / INV2O (PA7) function. 0 / 1 : disable / enable
0	-	-	Reserved.

#### 3.2. Code Example

*Open IO\_INV2 and IO\_INV3 Function :*

```
$ MISC2    PB3_to_PB4, PA6_to_PA7 ;
```

*Only open IO\_INV2 Function :*

```
$ MISC2    PA6_to_PA7 ;
```

*Only open IO\_INV3 Function :*

```
$ MISC2    PB3_to_PB4 ;
```

*Disable All IO\_INV Function :*

```
$ MISC2    ;
```

#### 4. RFC (Resistance to Frequency Converter) Functional Description

Resistance to Frequency Converter (RFC) is combined with RC oscillator and RFC 16-bit counter, the RFC block diagram is shown as Fig. 1, 10 channels (RFC1 ~ RFC10) is supported for C-Type operating mode and 9 channels for R-Type operating mode. The 16-bit RFC counter will start/stop counting when writing 1/0 to the bit 4 of RFC control register (rfcc.4).

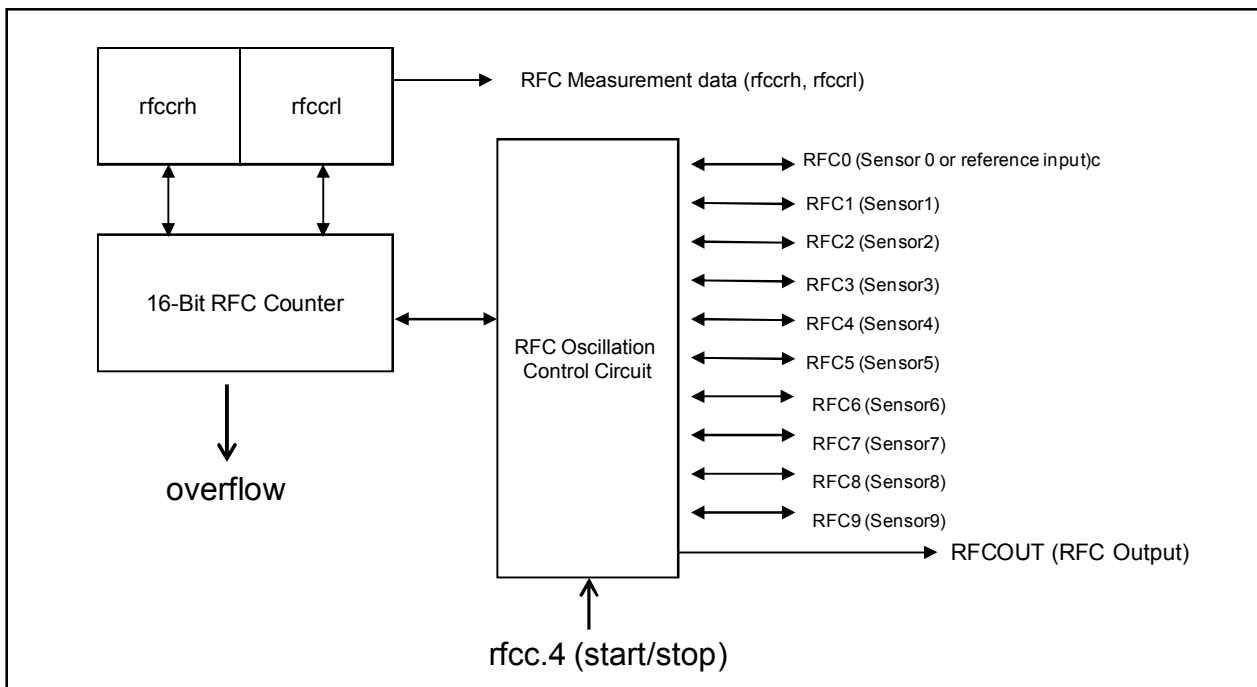

Fig. 1: RFC block diagram

## 4.1. Register Setting

### 4.1.1. RFC Control Register (*rfcc*)

Bit	Reset	R/W	Description
7 - 5	111	W/R	RFC channel selector
			If <i>rfcc.0</i> =0
			000: PA4 (RFC0) (For C-type only) 001: PA0 (RFC1) 100: PA3 (RFC2) 101: PB7 (RFC3) 110: PB6 (RFC4) 111: disable (default)
			000: PB4 (RFC5) 001: PB3 (RFC6) 010: PB2 (RFC7) 011: PB1 (RFC8) 100: PB0 (RFC9) Others: reserved
4		WO	<b>Start/Stop RFC operation.</b> <b>When writing "1" to this bit, it will start RFC counter.</b> <b>When writing "0" to this bit, it will stop RFC counter.</b>
3		W/R	RFC Mode: 0 / 1 : R-type / C-type
2		RO	Overflow flag.
1	-	W/R	Output Enable. 0 / 1 : disable / enable
0	-	W/R	RFC Channel select extension. This bit is used to extend the definition of bit[7:5].

### 4.1.2. RFC Counter Result High Register (*rfcchr*)

Bit	Reset	R/W	Description
7 - 0	-	RO	Bit[15:8] of RFC counter.

### 4.1.3. RFC Counter Result Low Register (*rfcrl*)

Bit	Reset	R/W	Description
7 - 0	-	RO	Bit[7:0] of RFC counter.

## 4.2. Code Example

```

$ RFCC PA0, R_TYPE, Start;
.delay (1000);
$ RFCC ;
A = rfcrl;
.
.
A = rfcchr;

```

### 4.3. R-Type

The application circuit of R-Type RFC is shown as Fig. 2, the RefC is the reference capacitor and RefR is the reference resistance, the Sen2R ~ Sen9R is the resistance to be measured and RFC0 acts as input buffer with Schmitt trigger to obtain the clock source of RFC 16-bit counter.

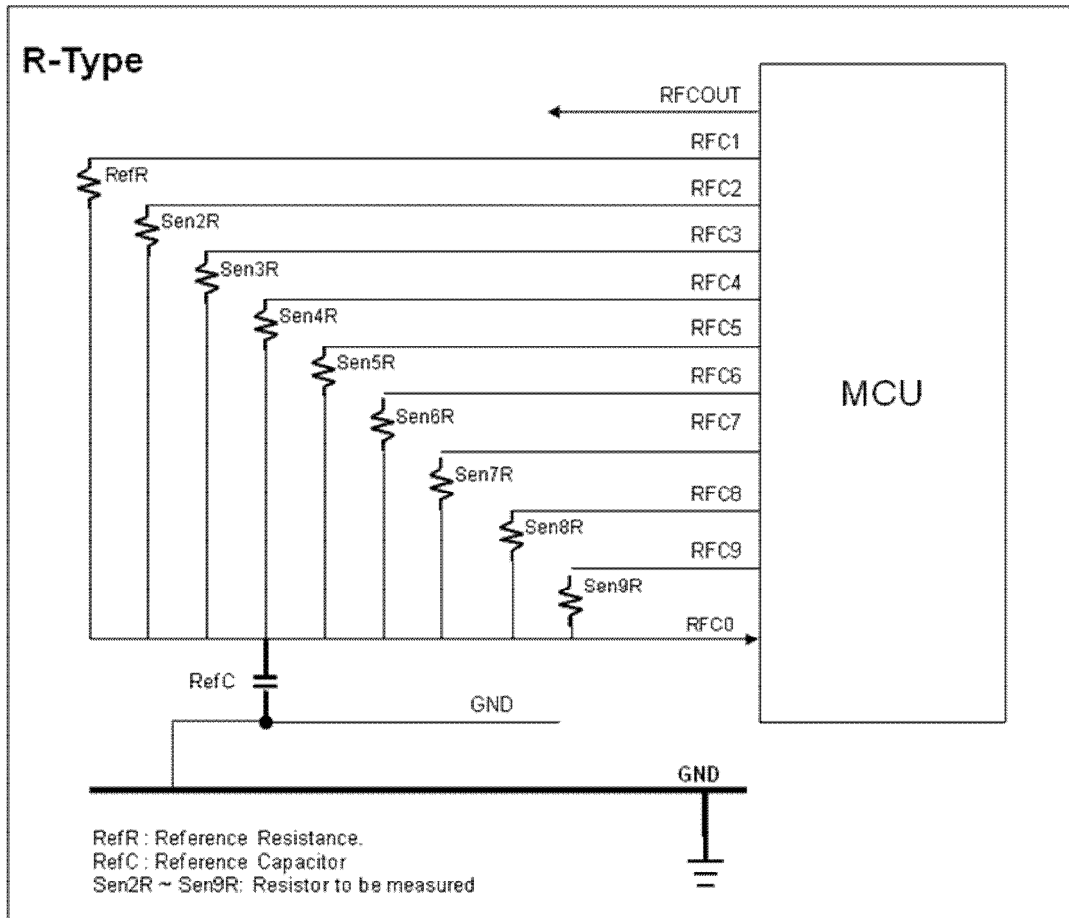

Fig. 2: Application circuit of R-Type RFC



The charging/discharging mechanism of R-Type is shown as Fig. 3. Before enabling the RC oscillation, one of RFC1~ RFC9 will be selected charging Path(A) comes from the selected channel and through its correspondent resistance SenR to RefC, the voltage level of RefC will be charged to high level, and then, the RC oscillator will turn to discharge Path(B).

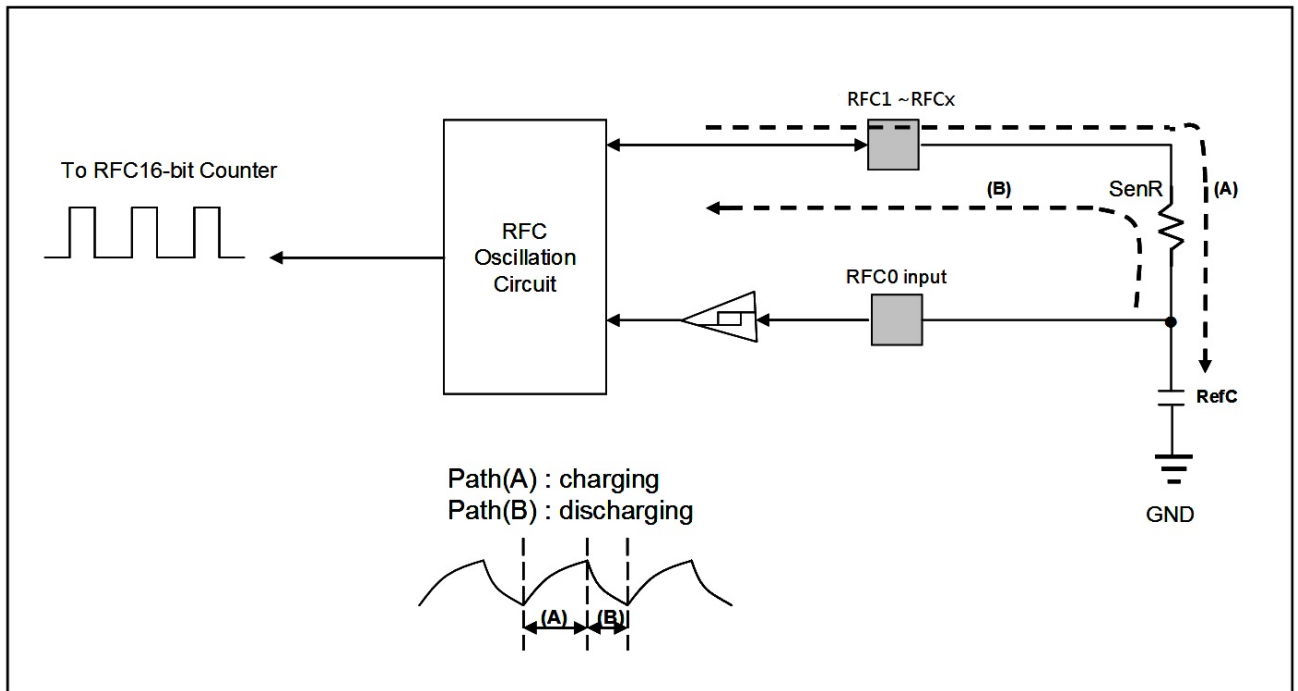

Fig. 3: Charge / discharge mechanism of R-Type

The waveform of RC oscillation and RFC output is shown as Fig. 4.

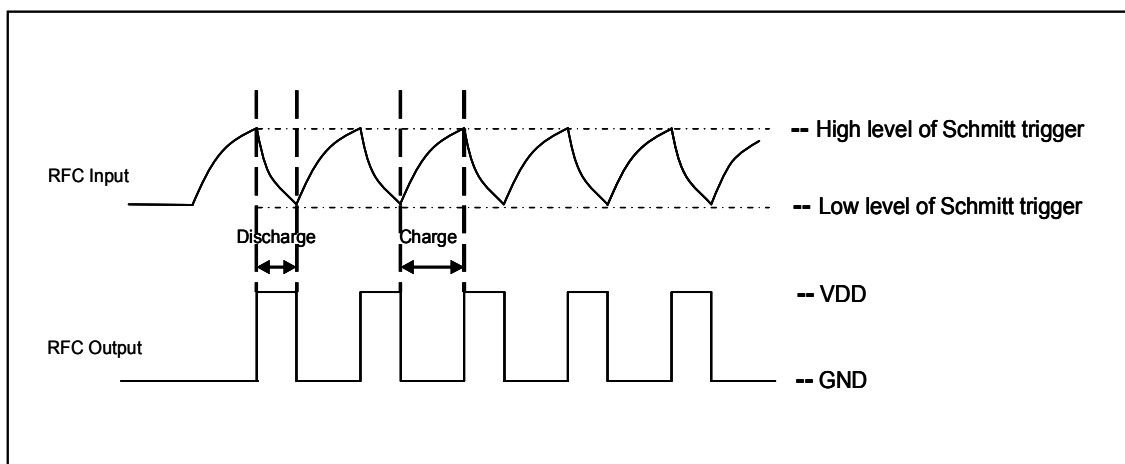

Fig. 4: Waveform of RC oscillation and RFC output

The 16-bit RFC counter is controlled by bit 4 of RFC control register (rfcc). Writing rfcc.4=1 to start counting and 0 to stop counting, shown as Fig. 5.

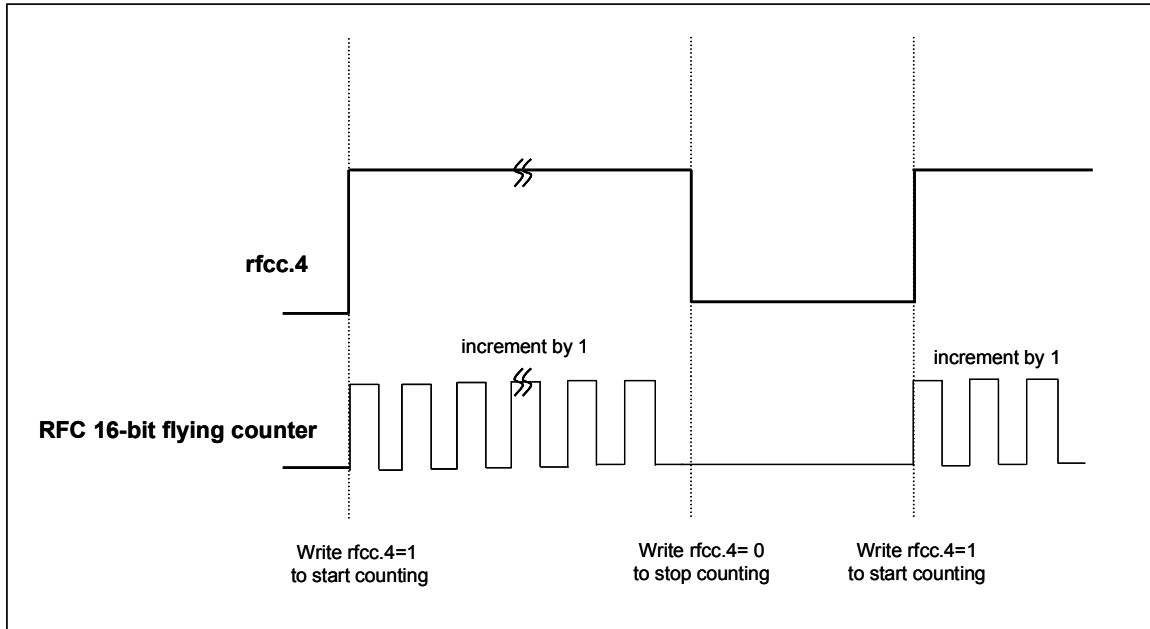

Fig. 5: Writing to start/stop RFC counting

Although 16-bit RFC counter is controlled by software, however, Timer16 can be used to generate a fixed timing period to start/stop the RFC counter. By comparing the counter values via charging/discharging RefR and SenR, we can have the relationship of SenR and RefR and obtain the accurate SenR.

**4.4. C-Type**

The application circuit of C-Type RFC is shown as Fig. 6 and its charging and discharging mechanism as Fig. 7. Each channel has its own resistance and capacitance, charging/discharging can be operated independently. Charging path (A) comes from supply voltage VDD and discharging path (B) to the RFC channel.

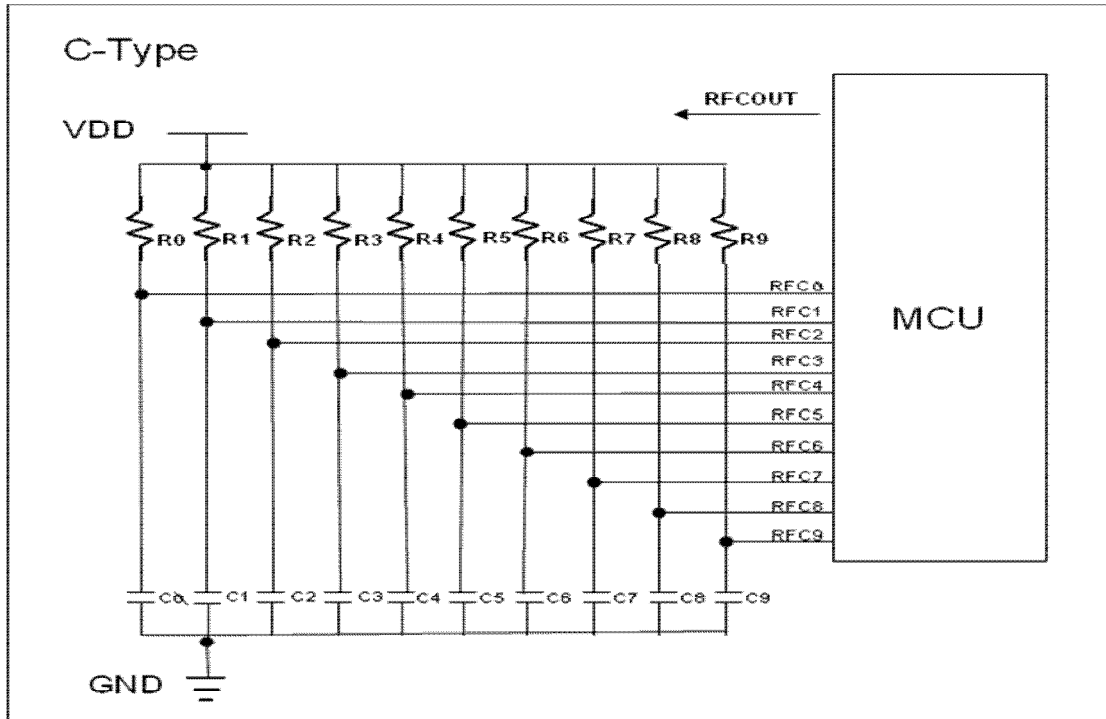

Fig. 6: Application circuit of C-Type

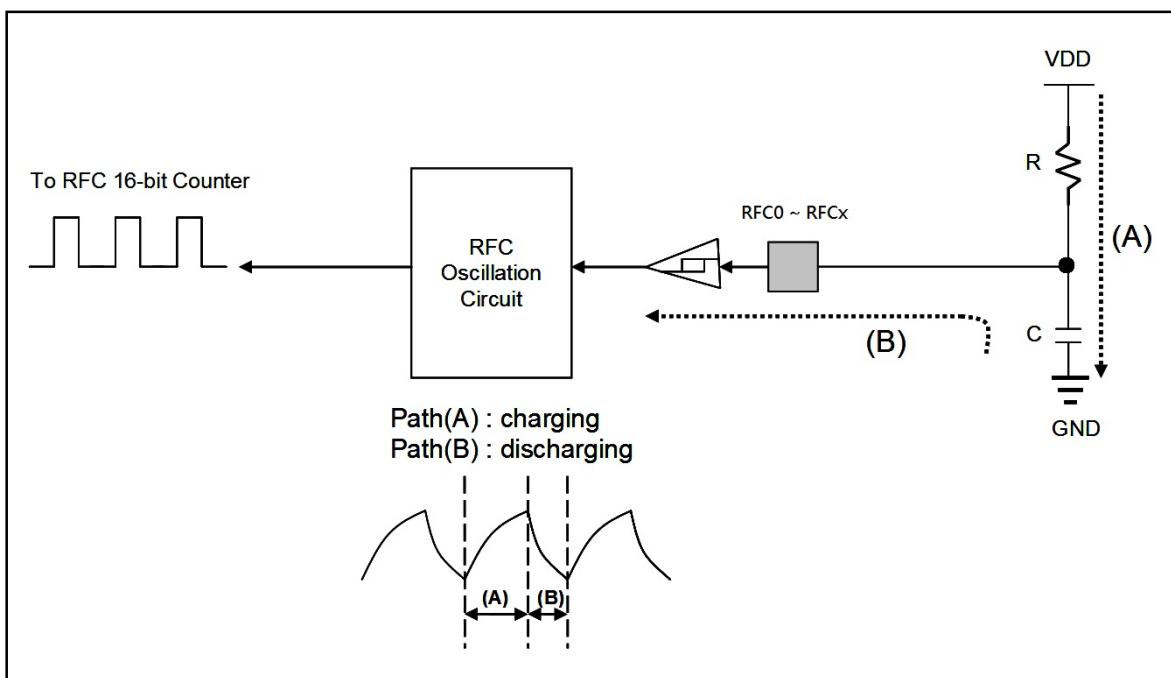

Fig. 7: Charging and discharging mechanism of C-Type